















## 230x280 A-CNC-R

27x0,9

	 0°	 45°	 60°	 45°	 60°	
	210	180	110	x	x	x
	150*	110*	80*	x	x	x
	280x200	180x170	100x70	x	x	280x120
						
3x400V 50 Hz	1,5	20-100	2720x27x0,9	780		
L	B	Hmin	Hmax	V		
2305	2260	1405	1780	800		



230x280  
A-CNC-R

OPTION  
STANDARD

230-F

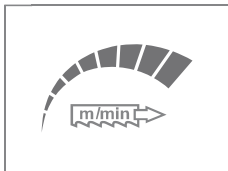

230-PUD

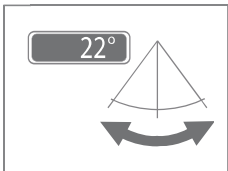

240-CK

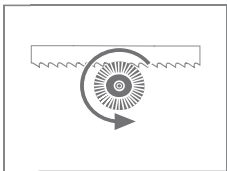

230-DPP

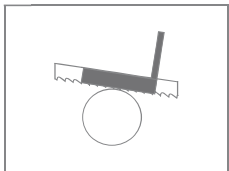

PEGAS-BRP

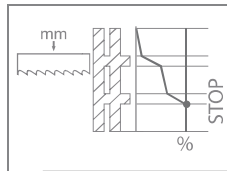

230-HP-A

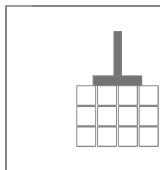

MINI LUBE 27-34

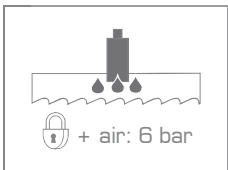

R 290

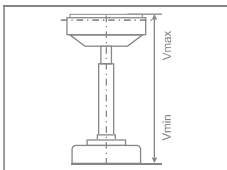

LIGHT L1

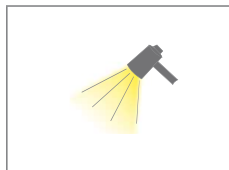

MITSUBISHI HMI 7"



230-RTS-A

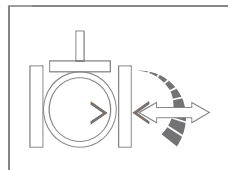

RB 200

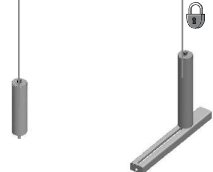

RBS 200/290  
+RB



RHS 290  
+RBS+RB



230-VTT

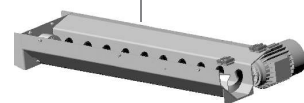

RD 1000/290

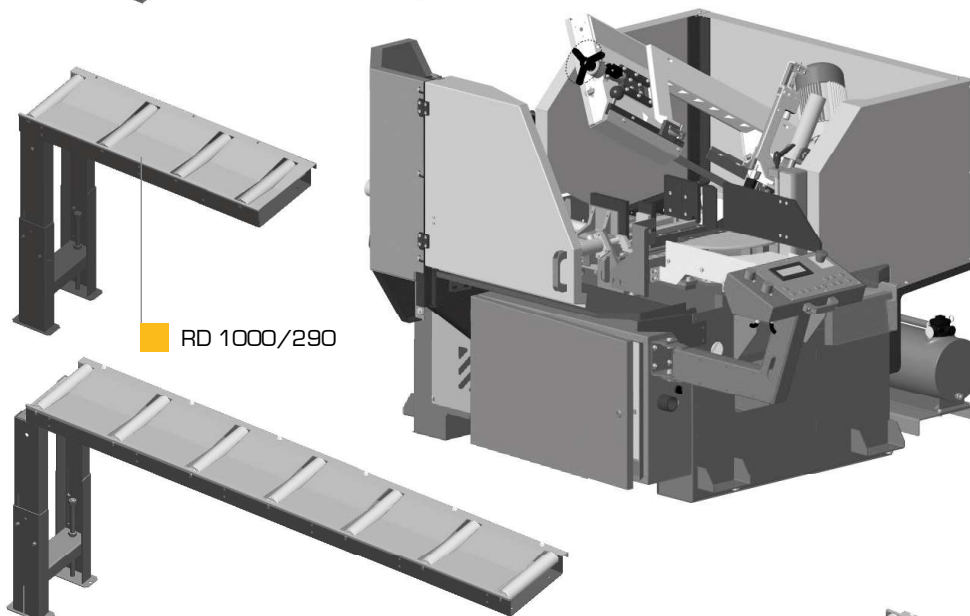

RD VR-290

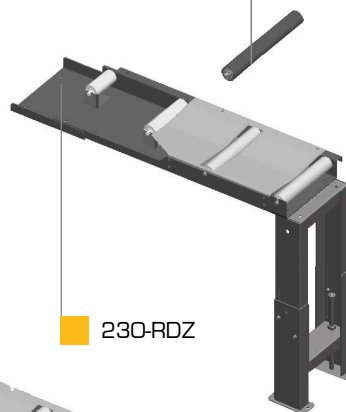

230-RDZ



RD 2000/290

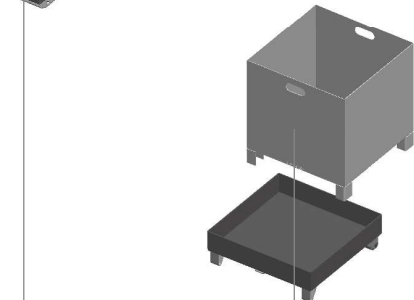

BOX-PCS



BOX-TAH

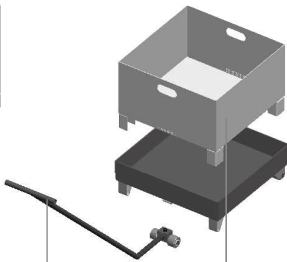

BOX-TRI

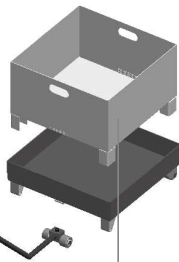

RD 1000/290



RDN

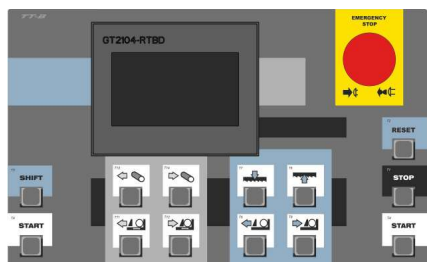
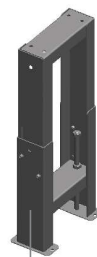

CONTROL PANEL: MITSUBISHI NC

## 230x280 A-CNC-R

- výrobce si vyhrazuje právo provádět změny  
technických údajů, technické údaje odpovídají 1.1.2020  
/ producer has the right to make changes of technical data,  
technical data are valid on 1.1.2020

- pila na fotografii není vždy v základním provedení,  
uvedené rozměry odpovídají stroji v základním provedení  
/ the machine in the picture is not always in the basic version,  
mentioned diameters are for machine in basic version

\* doporučená hodnota. Při překročení doporučeného  
maximálního průměru není možné garantovat výkon  
pilového pásu!  
/ recommended value. The blade performance cannot  
be guaranteed  
when the recommended diameter is exceeded!

☒ - řezání svazků bez horního přitlaku  
/ cutting of the bundle without top clamping



PEGAS - GONDA s.r.o.  
Čs.armády 322, 684 01 Slavkov u Brna,  
CZECH REPUBLIC

www.pegas-gonda.cz  
00420-544 221 125 (126) | pegas@gonda.cz